

bañera Next integral

Español Instrucciones de montaje

English Installation instructions

Français Instructions de montage

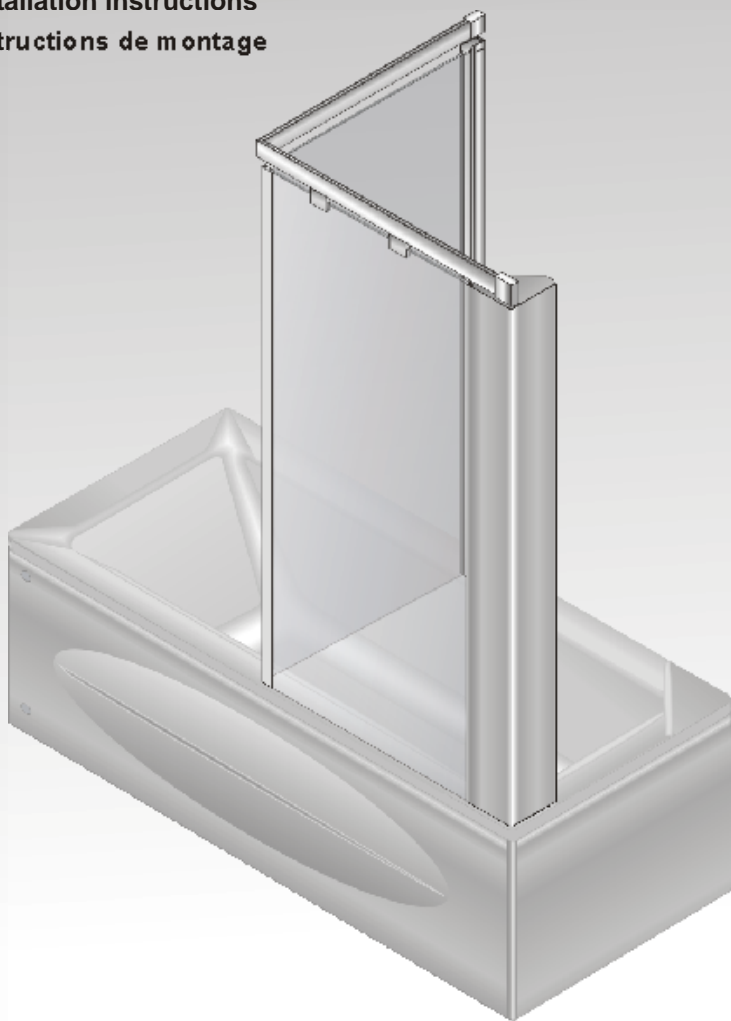

 **gala**

Español**OBSERVACIONES**

Este producto ha sido diseñado, fabricado y verificado por nuestro personal técnico.

La instalación de la bañera Next integral debe ser efectuada por personal autorizado por Cerámicas Gala, S.A.

EL NO CUMPLIMIENTO DE ESTA NORMA IMPLICA LA PERDIDA DE LA GARANTÍA DEL PRODUCTO.

A continuación les exponemos los puntos básicos para realizar una correcta instalación.

Se recomienda colocar llaves de corte en las tomas de agua.

Antes de proceder a su instalación, comprobar que los componentes no han sufrido ningún daño durante el transporte.

Todos los componentes de la bañera Next integral debe conservar sus protecciones hasta el final de la obra, con el fin de prevenir posibles desperfectos.

Para manejar la columna se cogerá por el armazón. No se utilizarán los accesorios de ducha como asideros durante la manipulación de la columna.

El transporte de los componentes se hará de forma cuidadosa evitando su arrastre y la sujeción por las tuberías, en el caso de la columna.

Cuando se apoye algún componente en suelo o pared se extremarán los cuidados para evitar roturas de los vidrios o deformaciones del aluminio.

Es conveniente purgar las tuberías antes de realizar las conexiones de agua caliente y agua fría.

Determinado tipo de calzado puede rayar la superficie de la bañera, por lo que recomendamos, se proteja este mediante un paño o plástico durante el montaje.

English**OBSERVATIONS**

This product has been designed, manufactured and checked by our technical staff.

The bathtub Next integral installation must be carried out by staff authorised by Cerámicas Gala, S.A.

FAILURE TO COMPLY WITH THIS RULE MEANS THE LOSS OF THE PRODUCT GUARANTEE.

Below we set out the main points for carrying out the pre-installation properly.

It is recommended to place stopcocks at the water outlets.

Before carrying out the installation, check that the components have not suffered any damage in the transporting.

All of the bathtub Next integral components must retain their protective elements until the end of the work, with the aim of preventing possible faults.

The shower column should be held by the frame when handling it. The shower accessory parts should not be used as grab bars during the handling of the column.

The transporting of the components will be carried out carefully, avoiding it being dragged and becoming fast by the tubes, in the case of the column.

When any element is leant on the floor or against the wall, care must be taken to avoid the glass being broken or the aluminium being dented.

It is appropriate to rinse the pipes out before making the hot water and cold water connections.

Certain types of footwear could scratch the surface of the bathtub. This is why we recommend you protect them with a piece of plastic or cloth during assembly.

Français**REMARQUES**

Ce produit a été conçu, fabriqué et contrôlé par notre service technique.

L'installation du modèle baignoire Next integral doit être effectuée par des techniciens agréés Cerámicas Gala, S.A.

LE NON RESPECT DE CETTE NORME ENTRAÎNE LA NON VALIDITÉ DE LA GARANTIE DE CE PRODUIT.

Afin d'effectuer une correcte installation du matériel, veillez à respecter les conditions présentées ci-dessous.

Il est recommandé d'installer le robinet d'arrêt au niveau des prises d'eau.

Avant de procéder à l'installation, vérifiez que les composants n'ont subi aucun dommage lors du transport.

Tous les composants du modèle baignoire Next integral doivent conserver leur protection jusqu'à la fin des travaux. Cette précaution permettra d'éviter tout défaut.

La colonne de douche sera manipulée à partir du bâti. Les accessoires de douche ne devront pas servir de levier lors de la manipulation de la colonne de douche.

Le transport des composants se fera avec soin en évitant de les prendre et soutenir par la tuyauterie, dans le cas de la colonne de douche.

Faites attention lors de la pose d'un composant sur le sol, ce qui pourrait entraîner des bris de verre ou des déformations de l'aluminium.

Il est recommandé de purger les tuyauteries avant d'effectuer les raccordements d'eau chaude et froide.

Certaines chaussures peuvent rayer la surface du baignoire. Il est par conséquent conseillé de le recouvrir d'un drap ou plastique lors de l'installation.

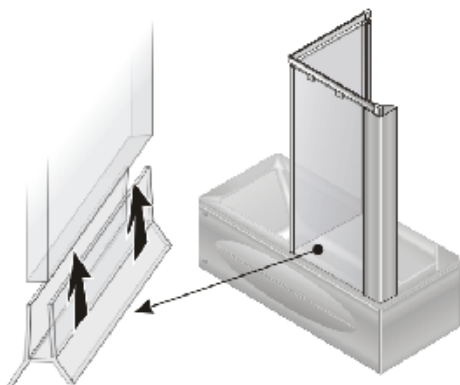

- Antes de extraer los vidrios del embalaje, coloque los perfiles inferiores de estanqueidad para evitar daños y golpes en la zona de apoyo de los cristales.

- Before extracting the glass from the packaging, put the inner waterproof covers in place so as to avoid damage and bangs in the support area for these.

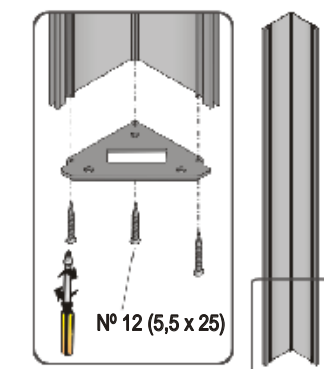

- Avant de retirer les verres de leur emballage, placez les joints d'étanchéité intérieurs pour éviter tout endommagement au niveau de la zone d'appui des vitres.

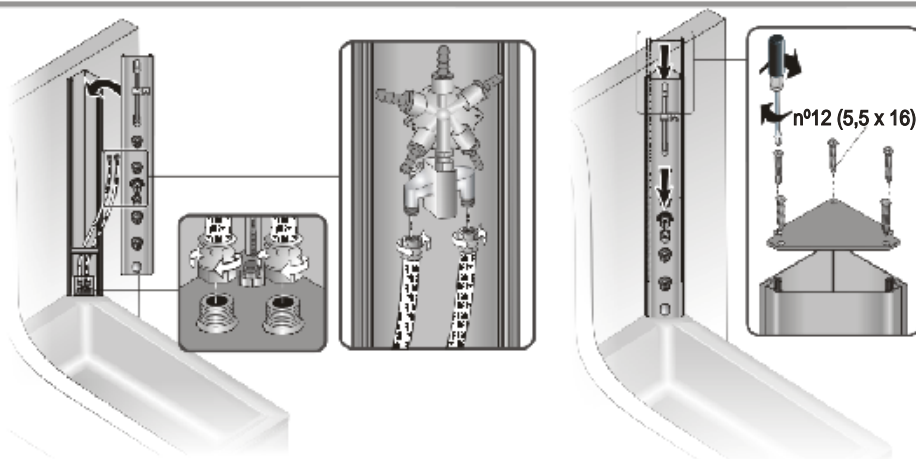
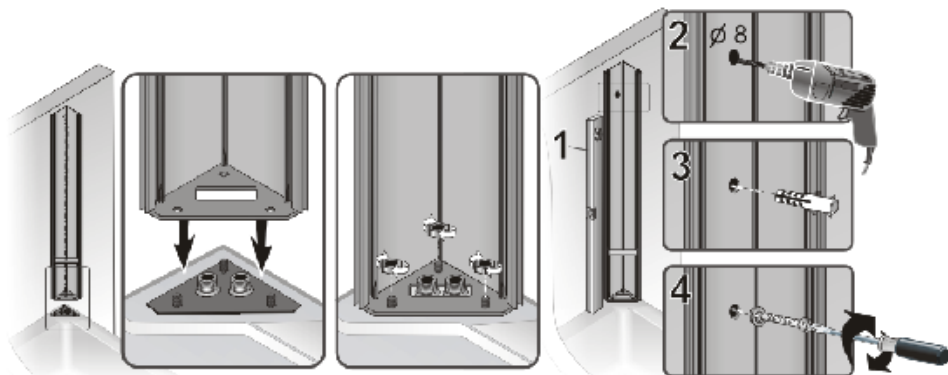

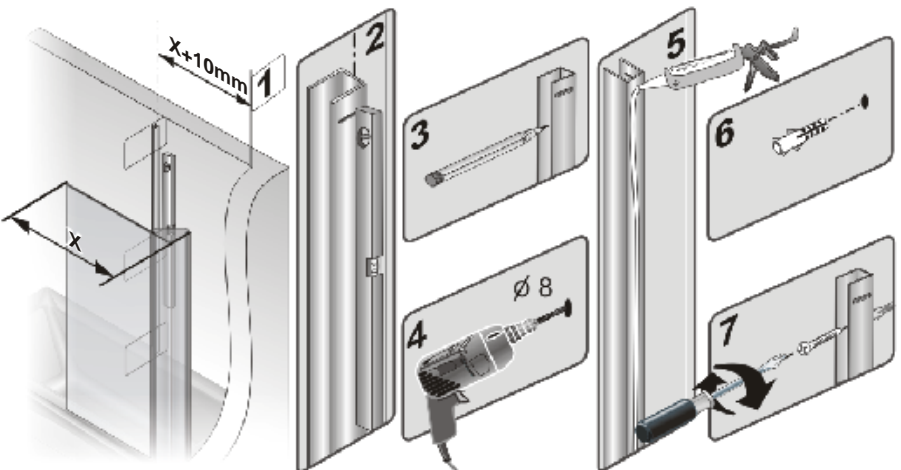
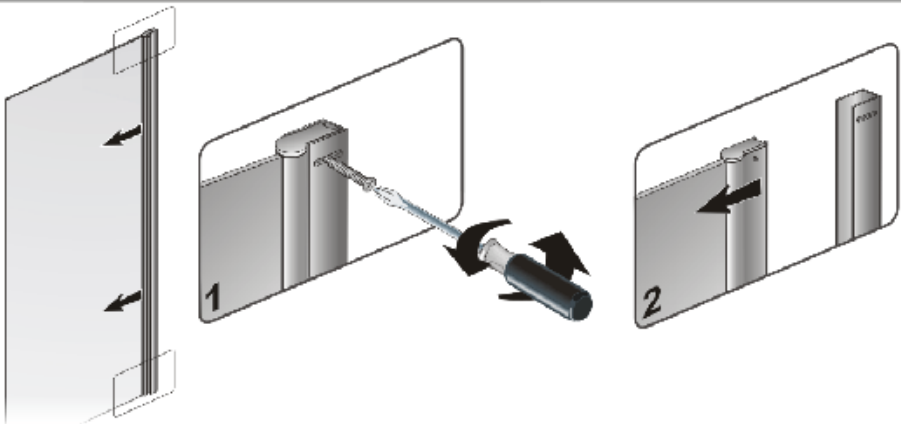
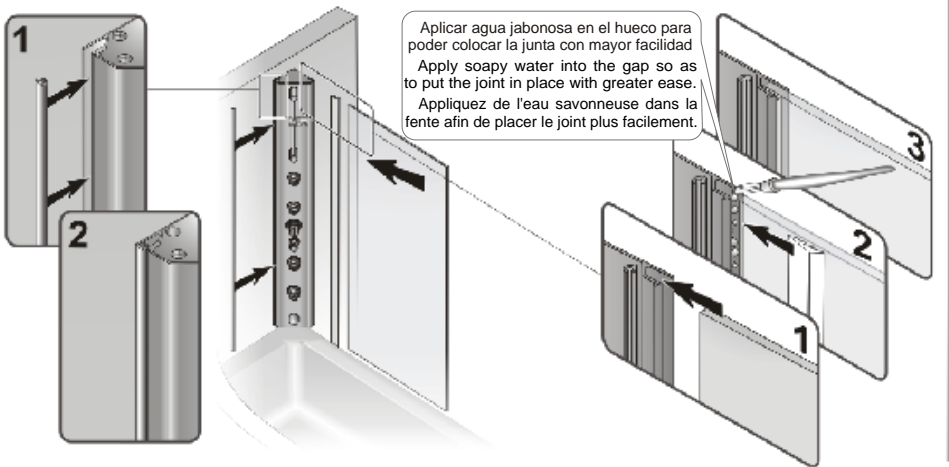

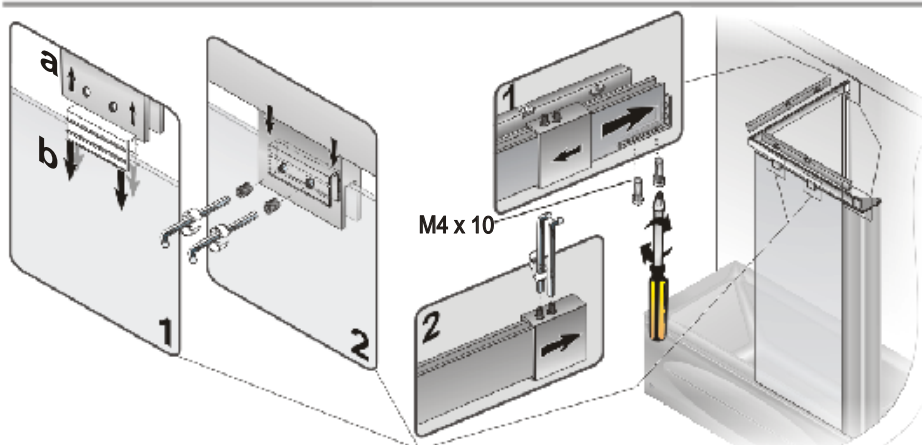
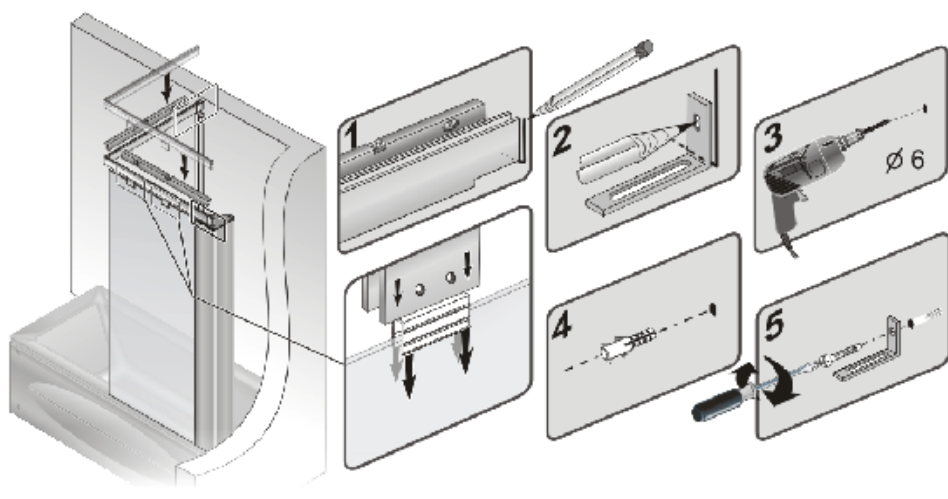
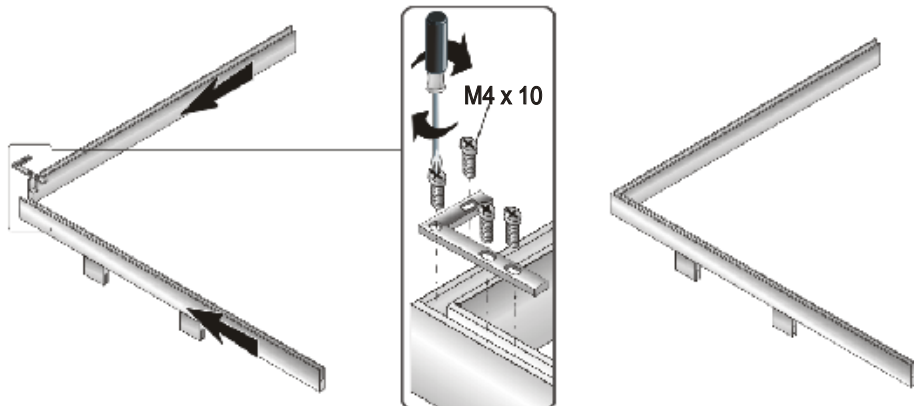

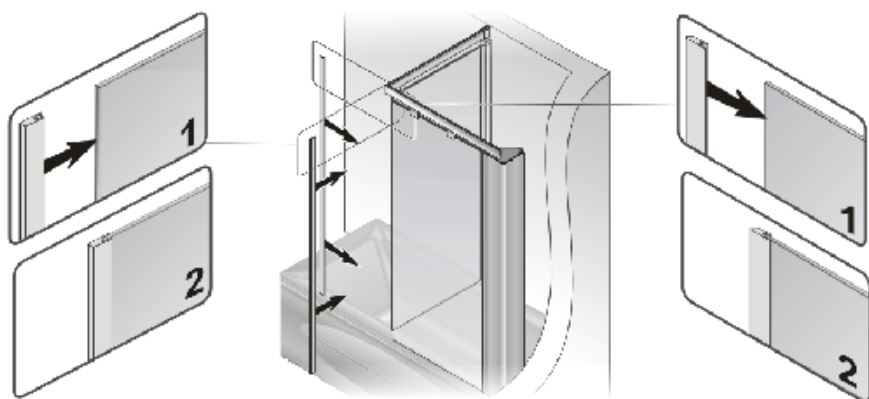
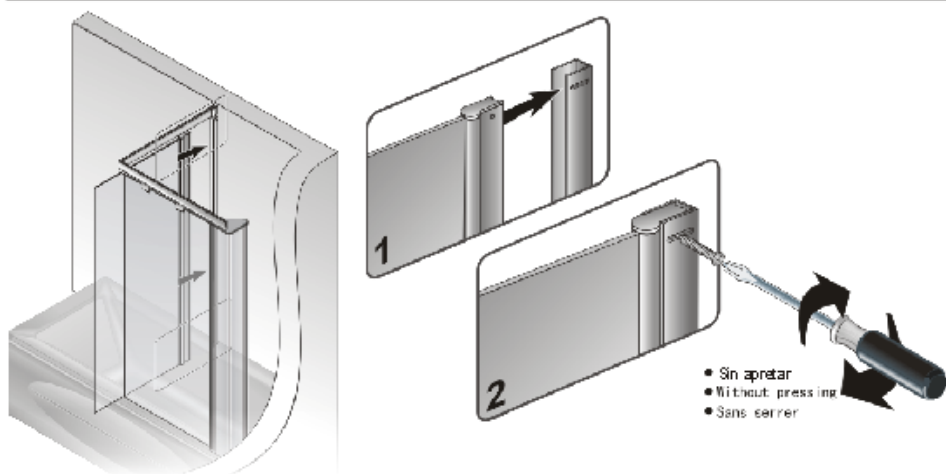
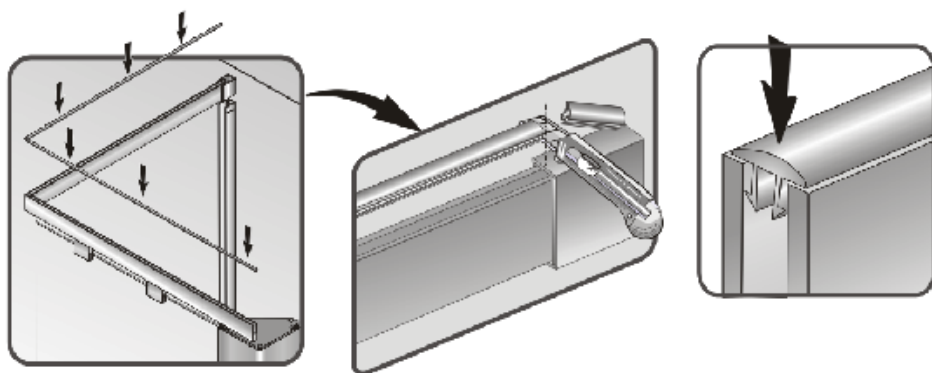

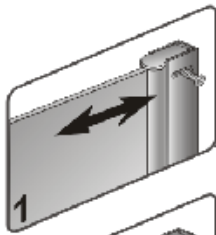

- Ajustar la puerta hasta juntar los dos perfiles imán y dejarlos paralelos.
- Fit the door until joining both magnetized profiles, leaving them parallel.
- Adapter la porte jusqu'à joindre les deux profils magnétisés, et à les laisser parallèles

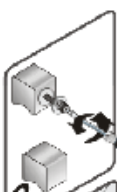
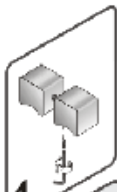
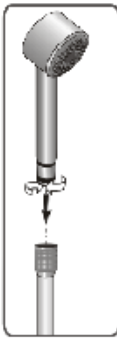
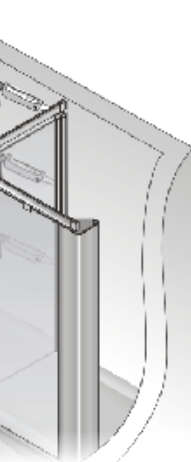
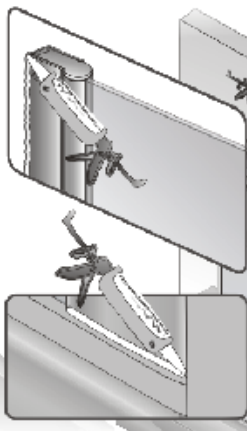
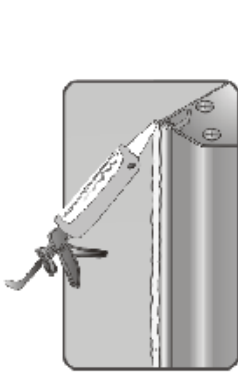
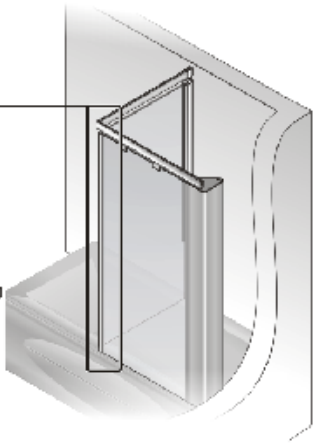
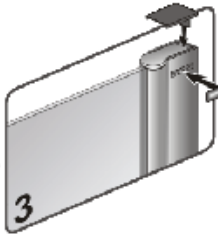
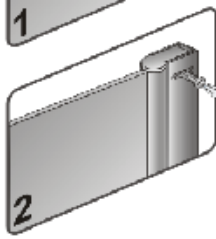



CERÁMICAS GALA, S.A.

Ctra. Madrid - Irún, Km. 244
Apartado de Correos, 293
09080 BURGOS - ESPAÑA
www.gala.es

 +34-947 47 41 00

 +34-947 47 41 03

e-mail: general@gala.es

G6360628000-01/10/05